

SERIOUS TRUCKS



4700 SF SB

Dump | Mixer | Crane
Snowplow | Roll-off | Sewer Vac



Serious trucks.™

DESCENDED FROM A LONG LINE OF WORKAHOLICS.



For a long time, you've wanted the quality and value of a Western Star. And now you can get it. We built the all-new Western Star 4700SB™ and 4700SF™ specifically to meet the demanding needs of vocational applications and today's tightening budgets. And we did it with input from you – the people who actually do the jobs. After all, no one knows what you need better than you do.

Of course, this new truck is still every bit a Western Star. Hand built with an unmatched attention to detail, just like we've done for over 40 years. Durable, reliable and rugged, designed to be lighter weight to save you money today and for years to come. So meet the new Star. Everything you need. Nothing you don't.



The all-steel, corrosion-resistant office.

No aluminum or rivets here. That just wouldn't be strong enough. Our galvanized steel cabs are built to keep you safe. Extra gussets and reinforcements, bonded instead of riveted, precision welded for strength, then dipped and protected with a 17-stage e-coat process for long-lasting corrosion resistance and a superior paint finish. Strength and longevity are the goals. We'd say they've been exceeded.

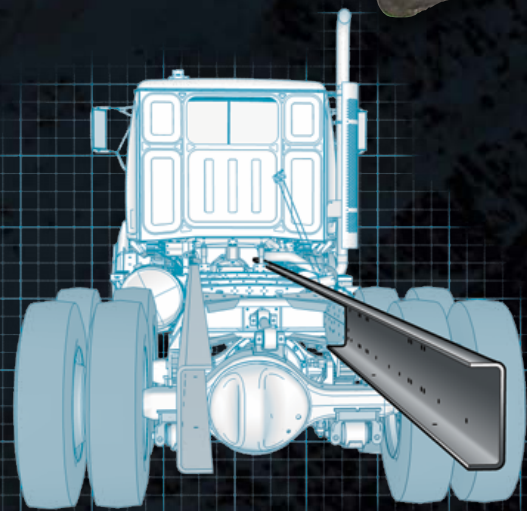

A NEW INTERIOR DESIGNED TO FIT THE WAY YOU WORK.

The interior of the all-new Western Star 4700 isn't built just to look pretty. It's built to make the job easier. A 72-inch-wide cab that's simple to get in and out of. Greater visibility. And a selection of new colors and finishes for a workplace that's brighter and easier to clean. One with loads of storage in the doors and between the seats, as well as features like customizable marine-grade switches and a hinged dash with exposed fasteners for improved serviceability. Yes, form does meet function.



HEAVYWEIGHT PERFORMANCE. WITHOUT THE HEAVY.

Yes, you can get strong and light. The half-inch-thick, single-channel frame rails available on the 4700 give you both. Rated at 3.2 million RBM, they also come custom drilled for your application, for added strength. And since they aren't stacked, it's harder for corrosion to start. Good idea.

THE RIGHT SIZE TO DO JUST ABOUT ANYTHING.

With a newly designed sloped hood and a 110-inch BBC, the Western Star 4700 offers unobstructed site lines with incredible visibility. Plus, its shorter overall length, when combined with a 55-degree wheel cut, gives you the maneuverability to get into – and out of – some pretty tight spots.

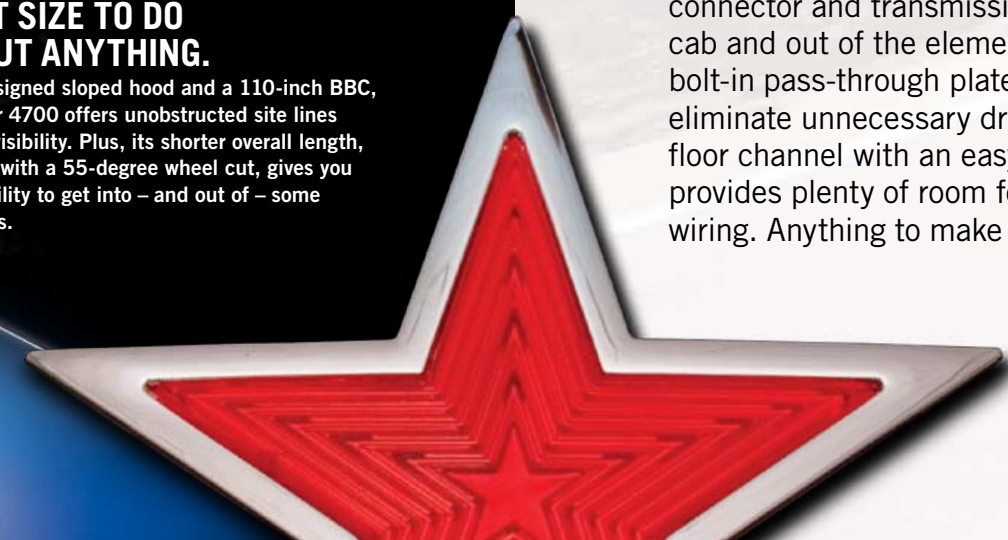

JUST WHAT THE BODY BUILDERS ASKED FOR.

We didn't only talk to owners. We talked to body builders, too. Which is why we built the all-new Western Star 4700SB™ and 4700SF™ with the features and body builder-specific options that reduce their installation time and save you money. Clean back of cab, in-cab batteries for clear frame rails, front frame extensions, ample room between the seats to install auxiliary equipment, and the list goes on. Just ask your dealer for more details.

Wiring made easy.

Few things can speed up an installation like smart wiring. So we put our body builder interface connector and transmission control unit in the cab and out of the elements. You'll also find a bolt-in pass-through plate in the cab floor to eliminate unnecessary drilling, and a dedicated floor channel with an easy-to-remove top that provides plenty of room for you to run your own wiring. Anything to make it easy.

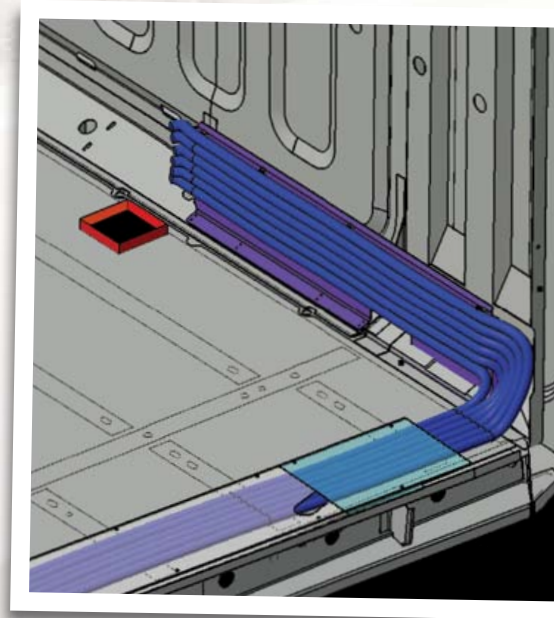

There's more than one way to run an exhaust.

Whether you need a clean back of cab or are looking for options to maximize fuel capacity, you'll find the exhaust options to make your truck a reality.

Pumps. Outriggers. And PTOs.

The 4700 comes standard with a stationary grille to make installing the equipment you need a little more convenient.

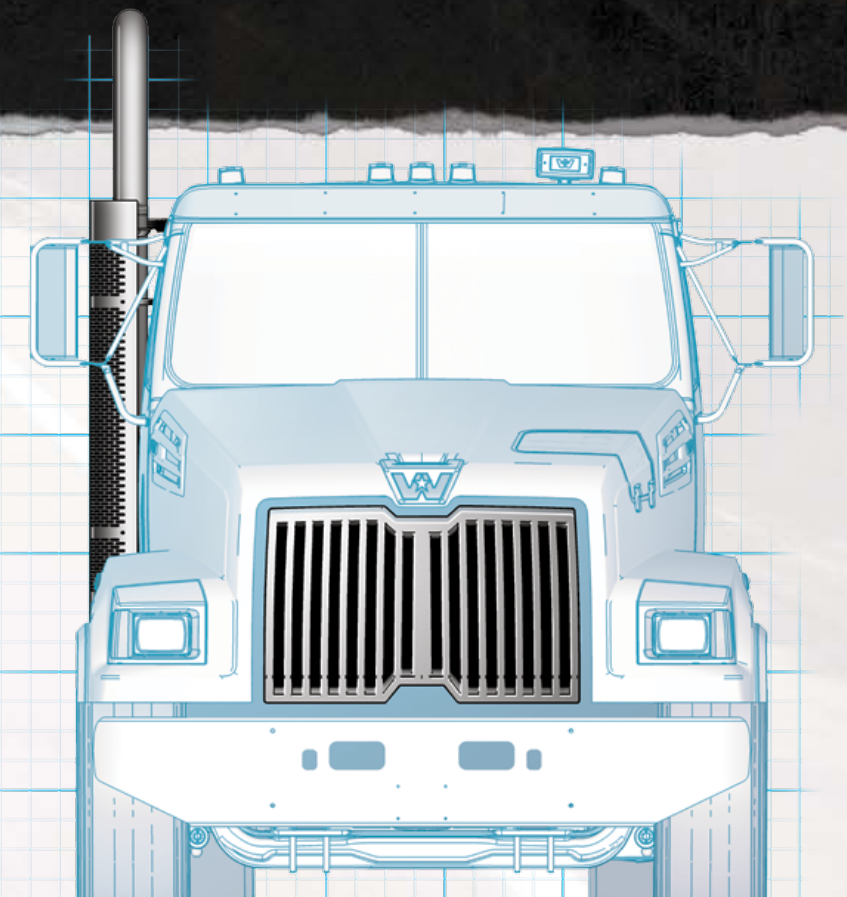

To us, close enough just isn't good enough.

When it comes to choosing an engine, close enough should never enter the conversation. That's why we offer a variety of Detroit Diesel® and Cummins® engine choices to give you the widest range of horsepower ratings for your application.

CUMMINS® ISC
260-350, 1000lb-ft.



CUMMINS® ISL
345-380HP, 1150-1300lb-ft.



DETROIT DIESEL® DD13
350-450HP, 1250-1650lb-ft.



SCR. JUST ANOTHER WAY TO MAKE YOU MONEY.

SCR (Selective Catalytic Reduction) is a simple yet cost-effective solution to meeting today's challenging emission requirements while improving engine power and efficiency. With reduced maintenance, better fuel economy and less regenerations, SCR helps increase engine performance and reliability for greater uptime. Whether you're driving to the job site or running the PTO when you're hard at work, SCR is the proven emissions system that provides a substantial return on your investment.



THE RIGHT TRUCK FOR THE JOB. ANY JOB.

The 4700 was engineered to be versatile. Easy to body up and built to last. The only question left to answer is how many you should order.



4700

SF SET FORWARD AXLE

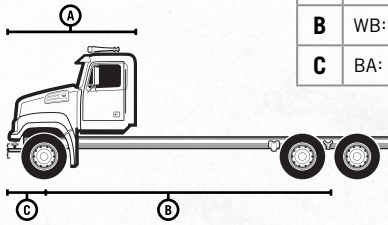

A	BBC: 110"
B	WB: Up to 300"
C	BA: 29"

SB SET BACK AXLE

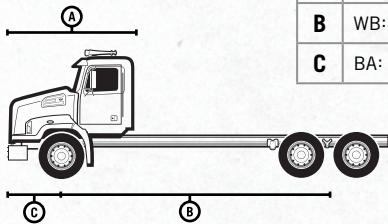

A	BBC: 110"
B	WB: Up to 300"
C	BA: 47"

PARTS AND SERVICE, WHEN YOU NEED THEM.

Our goal is to keep you working. That's why your dealer has an experienced service center team and carries a wide selection of parts, with access to an even greater variety through our expanding global network of parts distribution centers. You get the support you need to grow – no matter where you do business.

YOUR KIND OF FINANCING PROGRAMS.

Being part of the Daimler Truck Financial family means we can get you into the right truck at the right price with rates that are competitive with anyone, including banks. Plus, because we know the transportation and vocational business, it's simple to get the financing you need – and into the Western Star you want.

Daimler Truck Financial

Financing that works for you.



For the Western Star Dealer nearest you, call 1-866-850-STAR | WESTERNSTAR.COM

WS/MC-B-340. Specifications subject to change without notice. Western Star Truck Sales, Inc. is registered to ISO 9001:2000 and ISO 14001:2004. Copyright © 2011 Daimler Trucks North America LLC. All rights reserved. Western Star Truck Sales, Inc. is a subsidiary of Daimler Trucks North America LLC, a Daimler Company.