



Serious trucks.™

Rugged Vocational Trucks



WESTERN STAR®

WORK WHERE OTHER TRUCKERS WON'T



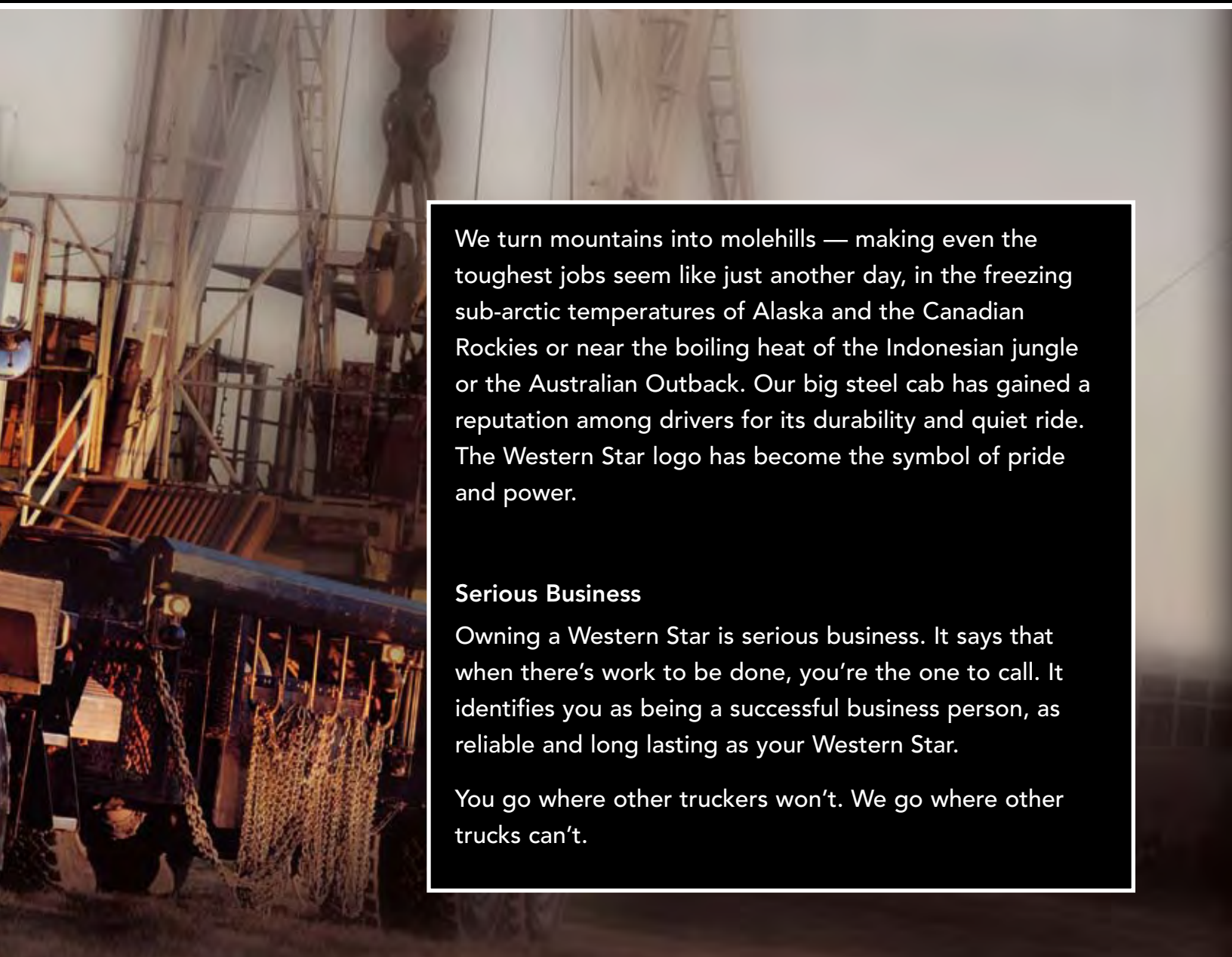

We turn mountains into molehills — making even the toughest jobs seem like just another day, in the freezing sub-arctic temperatures of Alaska and the Canadian Rockies or near the boiling heat of the Indonesian jungle or the Australian Outback. Our big steel cab has gained a reputation among drivers for its durability and quiet ride. The Western Star logo has become the symbol of pride and power.

Serious Business

Owning a Western Star is serious business. It says that when there's work to be done, you're the one to call. It identifies you as being a successful business person, as reliable and long lasting as your Western Star.

You go where other truckers won't. We go where other trucks can't.

GO WHERE OTHER TRUCKS CAN'T

We make serious trucks for serious truckers.
Engineered, built and supported for the serious business
of running a business.

Logging

Tough as a Lumberjack

Our durable, high-strength steel cabs are welded, not riveted. They're tough as a lumberjack. We offer many of the suspensions most highly rated by loggers, including our road-smoothing AirLiner™, Chalmers and the rugged TufTrac® suspension that offers extreme articulation and maximum traction across the roughest terrain.





To make it in this grueling business, you need a truck that meets your demands for durability, working components and maximum payloads — with the ride and handling that's right at home on a washed out logging trail — all backed by a dealer you can trust.

What you need is a Western Star.

Popular logging options include a severe-duty cab, heavy-duty cooling packages, tridem drive rear axles, heavy-duty suspensions, a wide range of logging bumpers and more.

If you need it, we can custom build it.

It's what gives us —and you — the toughness and versatility to get through today and come back for more.



To meet your power needs, Western Star offers a range of big bore diesel engines from the major suppliers, including Mercedes-Benz, Detroit Diesel and Caterpillar.



For severe logging applications, durable planetary gear rear axles — up to 110,000 lbs. — provide "deeper" gear reduction for improved performance and longevity.

Construction

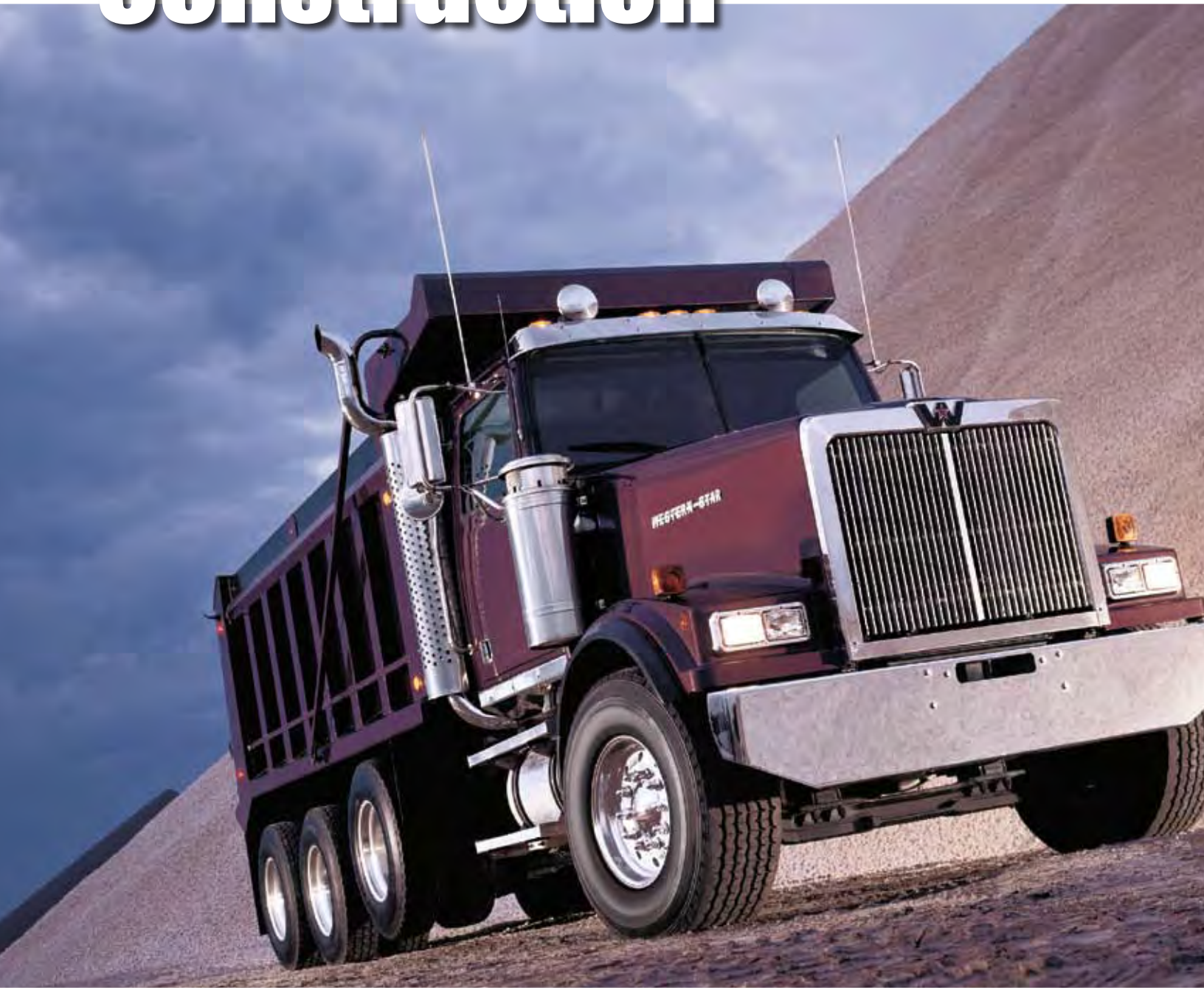

The Western Star Cab

Nothing is tougher than steel. The rugged Western Star Cab is constructed from double-sided, galvanealed stamped steel components. Stamped, shaped panels are welded together to form a frameless, monobody-type unit, allowing for greater cab size and strength without adding unnecessary weight. Even the door hinges — enclosed inside the side panels for a flush exterior surface — are made of high-strength, forged steel, providing proper alignment and long life.



Your job begins where the road ends. Western Star is as tough as it looks, weight-efficient and perfectly tuned to your operational needs.

Your Western Star can be custom spec'd with new industry technologies that offer the highest level of durability and weight savings.

If you need it, we can supply it.

Premium options like: a severe-duty cab; up to four factory-installed lift axles to help meet bridge law requirements; dual-steering front axles; tridem drive and all-wheel drive; plus custom mounting of components like fuel tanks to maximize ground clearance.



Air-Lift axles help satisfy Bridge Law Requirements.



Our TufTrac® rear suspension provides high articulation with uniform wheel loading, allowing you to traverse uneven job sites with ease.

Shot-Peened Steel

No frame is better suited to handle abuse than Western Star's 120,000 psi custom-pierced, custom-profiled, shot-peened steel rails. Crossmembers are steel fabricated, including stamped-steel flanges. There are no bolt-on extensions, no needless holes in the rail — nothing to compromise integrity.





8,000 Options

With an almost limitless list of options, we can configure up to quadruple frame rails for extreme load-bearing strength, and armor your truck with the ultimate in severe-service grille guards and bumpers. We can add up to 10x6 axle configurations and all-wheel drive.

We can provide 110,000 lb. planetary gears on the rear axles to enable the deepest possible gear reduction and to lessen the stresses on individual gears.



Severe Duty

In severe cold, or sweltering heat, wherever the ordinary rules of tonnage and terrain cease to apply, it's prime territory for Western Star. We set the standard for custom-building high performance trucks for extreme applications.

Where giants still prowl the earth, Western Star is there with a vocational pedigree, every component severe-duty certified.

175 tons GCW

The Western Star 6900 XD is rated up to 175 tons GCW and can traverse all types of off-road terrain.

From the highest horsepower engines available and severe-duty transmissions to the toughest steel plate bumpers and air cleaners tailored to the altitude and air quality in which you operate — your Western Star will be more than equal to the most extreme test ... with a ride that leaves the punishment outside the door.



The Severe Duty Cab option features a steel floor, additional internal cab reinforcements and the extensive use of structural adhesives in addition to our standard welded construction.

You and Western Star have a lot in common. You're unique, doing a special job with special needs. From Australian Road Trains to Maine loggers, we can custom-build a truck for unique applications. We're a custom fit.



For snow plow operators, for example, the key may be our integral front frame extensions up to 29-inches long. Or the biggest standard heater core in the industry, churning out 45,000 BTUs.

Your Western Star rescue vehicle, wrecker or utility truck will be tuned to maintain its legendary smooth and quiet operation. And to mesh perfectly with all on-board auxiliary electrical, air and hydraulic equipment.

Engine PTOs are available for every special requirement, including front and rear drives with factory crossmember clearance to speed installation time.

Nothing off the Rack

Right-hand drive. Twin steer front axle. All-wheel drive. 4x2, 4x4, 6x4, 6x6, 8x4, 8x6, 8x8 or 10x6 configurations. Two- and three-stage air cleaning systems. Extra heavy-duty electrical systems. Components mounted high on the rail for additional ground clearance.



A Custom Fit

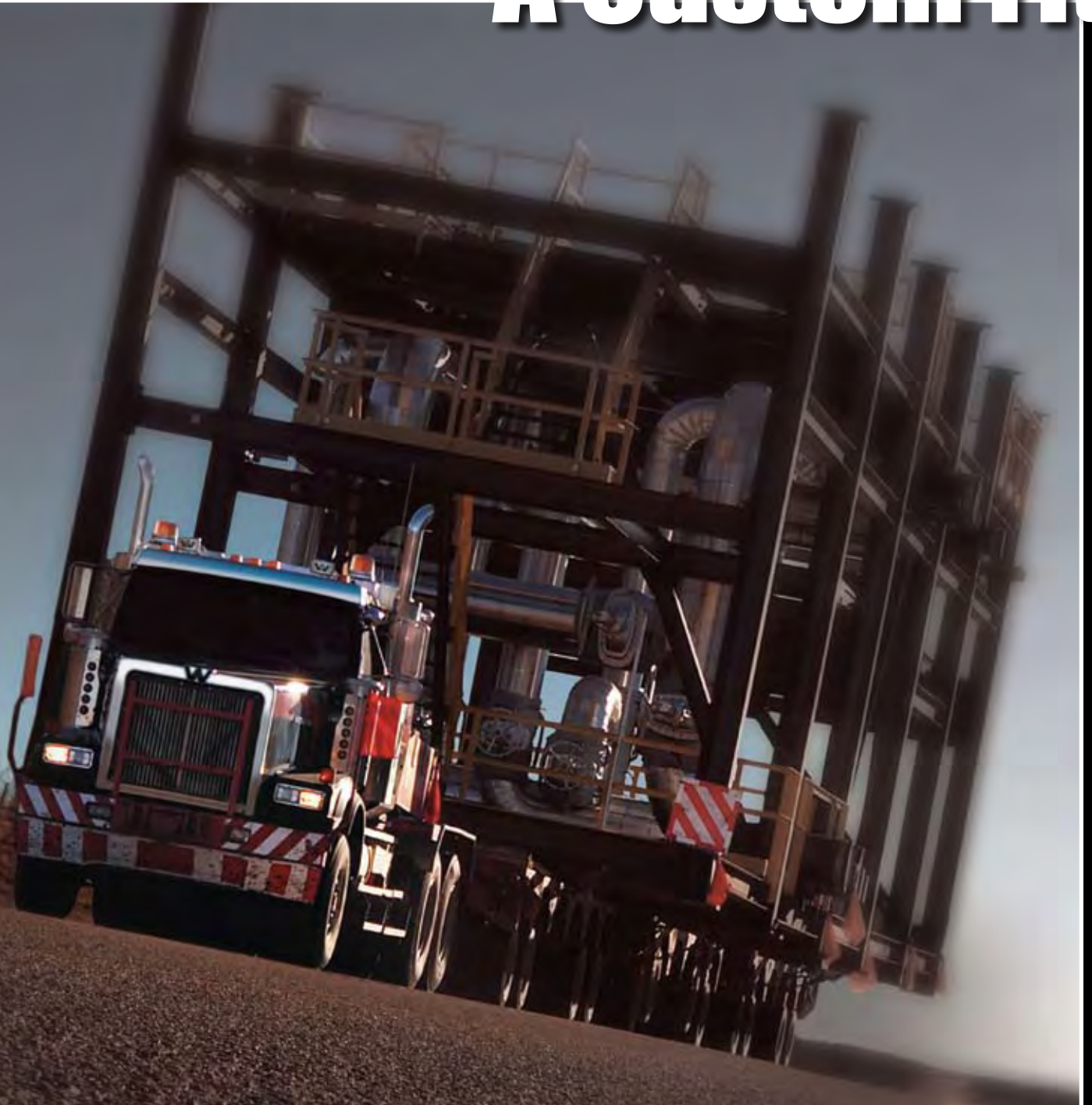

You don't buy off the rack. We don't make cookie-cutter trucks. If we did, we wouldn't be special. We wouldn't be a custom fit ... Western Star and you.



Big Power and Torque

A full range of electronic engines are available from Detroit Diesel, Mercedes-Benz and Caterpillar. Premium cooling packages are available in lightweight aluminum radiator cores up to 1750 square-inches and durable copper brass radiator cores up to 1875 square-inches. The massive cooling package combined with efficient fan technology allow for top performance in high horsepower applications up to 625 horses without the need for external hood modifications.

Transmissions

Powertrain offerings include the availability of the Allison 4000 Series Automatic Transmission, adding a greater degree of flexibility to a proven performer.

Premium Components

Serious work demands serious components. At Western Star we're always working to provide severe-duty, innovative options, some proprietary, and others from premium suppliers with a history of success in the vocational market.

For demanding on- and off-highway applications, we offer the TufTrac® — a rear suspension providing high articulation with uniform wheel loading, giving you the confidence to cross even the roughest job sites.

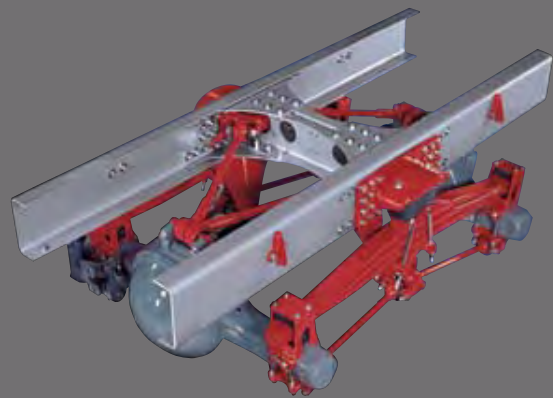

Western Star offers the most widely acclaimed suspensions in the industry.

The AirLiner™ (above) is known for its ability to cushion the ride for drivers while protecting truck components from stress and strain. With its oversized air bags and high range of travel, AirLiner™ can take the bite out of the roughest roads.

President's Office



You've worked a lot of hours to earn your seat inside the Western Star cab. It's like sitting down in the President's Office.

Our cab puts steel between you and the road. Known for its roominess and quiet ride, it takes all the punishment the job can dish out ... while pampering you. This, matched with traditional Western Star styling, provides you with looks that are second to none. Isn't that what a premium truck is supposed to do?



More Room

There's more knee and belly room behind the wheel than you'll need. Easy-action suspended brake and clutch pedals help take some of the work out of a work day. A wide range of premium seats and an available tilt/telescopic steering column relieve stress and contribute to safe, productive performance.



More Accuracy

The standard proprietary Star Gauge system — with Swiss made electronic stepper motors and LED illumination — provides unmatched accuracy and reliability. Data Star information center, available with Star Gauge, offers a user-selected display of critical vehicle performance along with trip-tracking functionality.



More Comfort

Our standard HVAC system includes four face outlets, four under-dash outlets, two main windshield defroster outlets with a radiator-mounted A/C condenser.

Taking your seat in a Western Star — it's a million dollar feeling.

Suspended brake and clutch pedals, LED illuminated rocker-type switches; backlit, easy-to-read Star Gauges; and optional 18" two-spoke, leather-wrapped woodgrain steering wheel



Phoenix Maroon – cloth



Dakota/Mesa
Maroon – vinyl



Phoenix Blue – cloth



Dakota/Mesa Blue – vinyl



Phoenix Tan – cloth



Dakota/Mesa Tan – vinyl

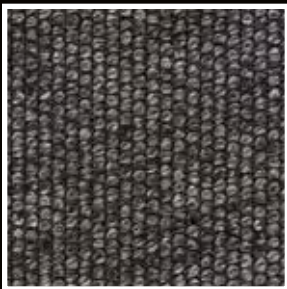

Phoenix Gray – cloth



Dakota/Mesa Gray – vinyl



Western Star is all about choices.

To help meet customer preferences and needs, Western Star is available in a variety of trim levels and colors.

Trim Levels/Colors

Dakota vinyl (with diamond stitching on door and back panels) is standard. Mesa vinyl (with diamond stitching and buttons on door panels and back panels) and Phoenix cloth (with diamond stitching on door and back panels) are optional.

Carpet floor covering and sculpted carpeting are available in colors that complement the upholstery along with durable black rubber floor mats for easy cleaning. Additional cab insulation packages are available to reduce road noise and to maintain cab and sleeper temperatures.

The large, two-piece windshield offers excellent visibility, while providing enhanced structural integrity and improved water sealing over the life of the vehicle. It can be easier and less expensive to repair than a one-piece windshield.

For a more comfortable and safe operating environment, the overhead console, including a passenger-side storage area, provides accessible storage space and convenient, dedicated mounting locations for satellite radio/CD and CB. Soft touch dashes are available in your choice of gray, tan or black.



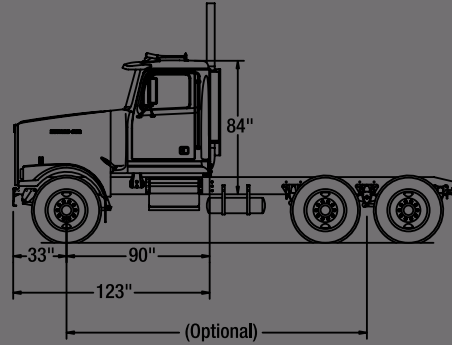

4900 FA
 Single piece
 non-sloped Hood
 Set-Forward Axle
 109" BBC; 33" BA
 123" BBC; 33" BA
 4x2, 6x4, 8x6

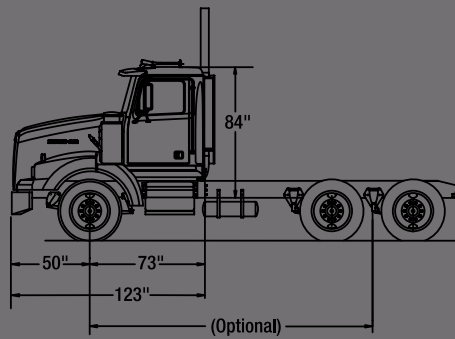

4900 SA
 Super Visibility Hood
 Non-sloped hood
 Butterfly hood
 with steel fenders
 Set-Back Axle
 109" BBC; 50" BA
 123" BBC; 50" BA
 4x2, 4x4, 6x4, 6x6, 8x6

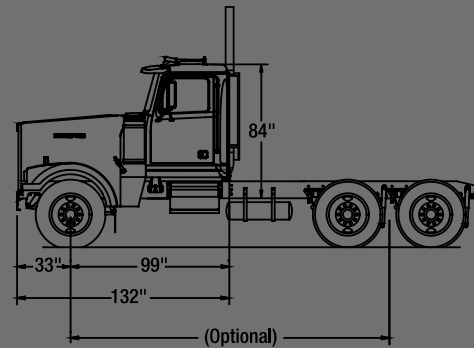

4900 EX
 Extended Hood
 Set-Forward Axle
 132" BBC; 33" BA
 6x4, 8x6

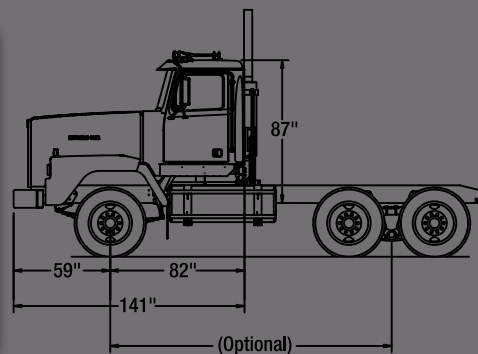

6900 XD
 Heavy duty fiberglass
 non-sloped hood
 Butterfly hood
 with steel fenders
 Set-Back Axle
 141" BBC; 59" BA
 6x4, 6x6

Models/Dimensions

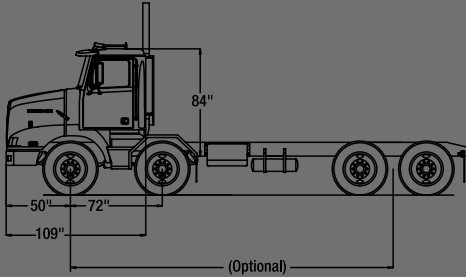

4900 SA Twin-Steer
 Super Visibility hood
 Set-Back Axle
 109" BBC; 50" BA
 8x4, 10x6

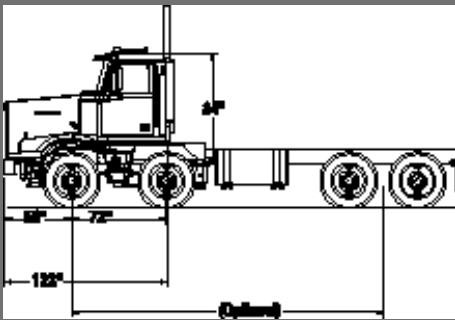

4900 SA Twin-Steer
 Super Visibility hood
 Non-sloped hood
 Set-Back Axle
 123" BBC; 50" BA
 8x4, 10x6

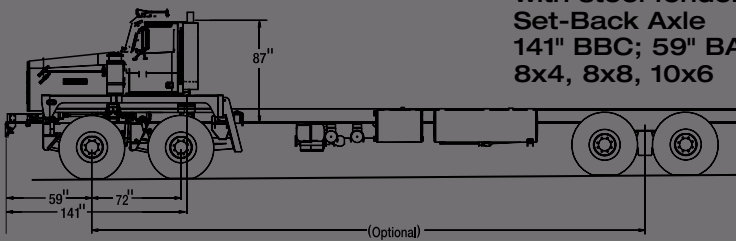

6900 XD Twin-Steer
 Butterfly hood
 with steel fenders
 Set-Back Axle
 141" BBC; 59" BA
 8x4, 8x8, 10x6



Serious Uptime

A truck is either running or not running, making money or wasting time. It's hard to get serious about a truck that is always down, draining your bottom line. Caring for your Western Star is easy. It's built to run, designed to last ... and is incredibly simple to maintain.

Durable

Rubber-isolated, frame-mounted radiators are protected from frame twisting. Gates Blue Stripe hoses and constant torque clamps are heat and oil resistant, increasing cooling system reliability and uptime.

Built for Reliability

Standard nylon braid and optional wire braid air lines deliver maximum life and reliability. Push-connect air connections eliminate guesswork and reduce labor time for air line service or repairs. Air lines and electrical wiring harnesses mount inside the frame rail near the upper frame flange and are secured to 3/8" weld studs placed 18" apart using rubber isolated P-clamps to prevent chafing and rubbing.

Easy to Maintain

The electrical system is robust and easy to service. The Electronic Control Center (ECC) protects circuits against short circuits and overloads.

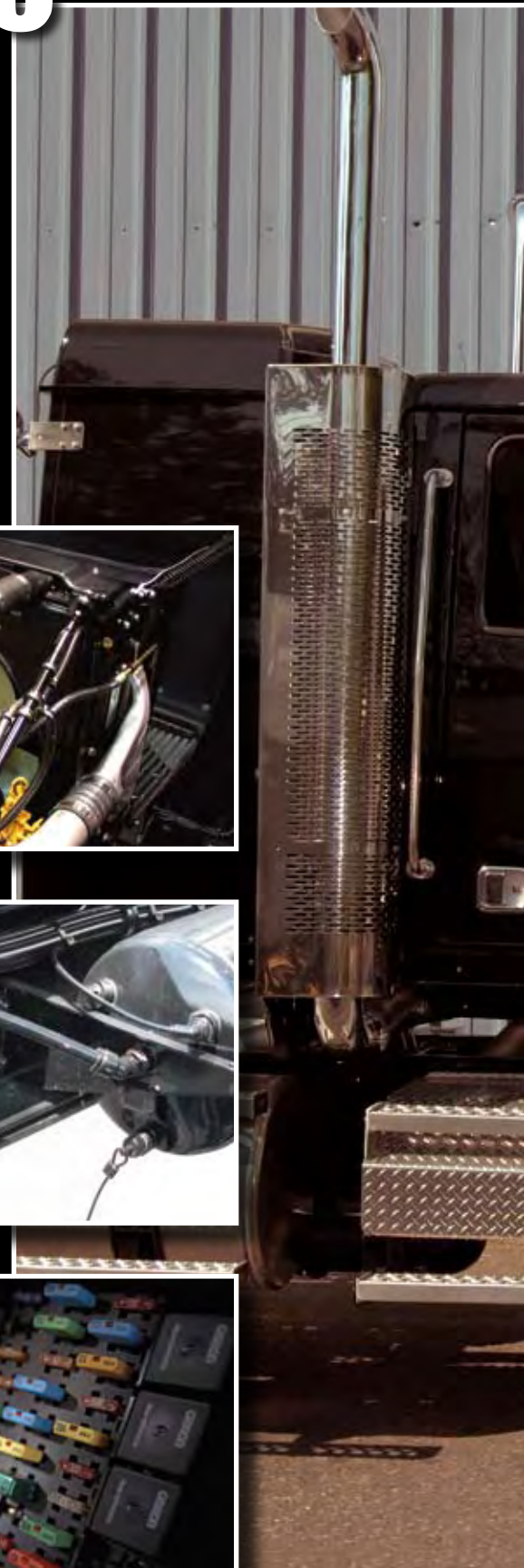
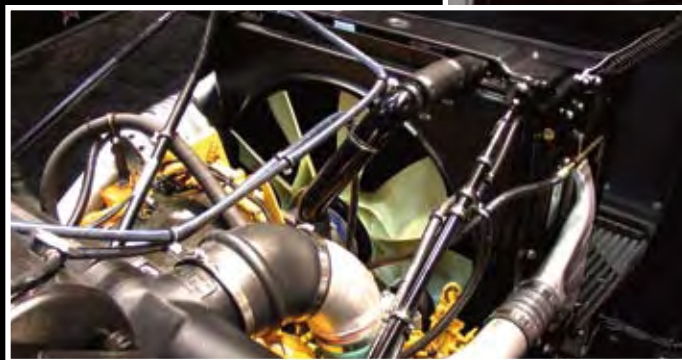

The hood tilts a full 90 degrees, allowing easy underhood access to the engine, wheels and suspension. This helps ensure that routine maintenance checks are regularly made.



For the whole story, ask a Western Star dealer to take you on a complete walk-around. It's a tour worth taking.

Serious Support



Driving a truck is one thing; running a business is another. Your Western Star dealer understands both. He's part of a our network of over 300 strong and rapidly growing throughout North America.

They're serious trucking professionals, whose business it is to know your business and to be open for business when you are.





DaimlerChrysler Truck Financial

Buying and operating a Western Star has never been easier.

Ask your nearest Western Star dealer for information on DaimlerChrysler Truck Financial's full range of financing options. Flexible financing packages are available, custom designed for the individual owner or small fleet.

The way you finance your Western Star can be as individual as your truck specs. It's how we do business at Western Star, one truck at a time, one customer at a time.

Custom Fit Programs

No two customers are exactly alike; at Western Star no customer support programs are exactly identical. Freedom of choice and flexibility begins with the way a customer spec's his or her trucks and extends through the way the trucks are maintained and supported through their productive lives.

Your dealer can custom fit a support program as individual as your truck specs.

Parts and Service

After the sale, our parts and service division is equipped with everything it takes to keep your Western Star up and running. You can get roadside assistance 24 hours a day by calling 1-866-850-STAR.

Many of our dealerships are open 24/7 to better meet your needs.

Anything less wouldn't be Western Star.

For directions to the Western Star dealer nearest you, call 1-866-850-STAR or visit us online at westernstartucks.com



For the Western Star Dealer nearest you, call 1-866-850-STAR
www.westernstartrucks.com

WS/MC-B-228. Specifications subject to change without notice. Western Star Truck Sales, Inc. is registered to ISO 9001:2000 and ISO 14001:2004. Copyright © Daimler Trucks North America LLC. All rights reserved. Western Star Truck Sales, Inc. is a subsidiary of Daimler Trucks North America LLC, a Daimler Company. 1/08, MMS 58074

Daimler Truck Financial

Financing that works for you.